

HYDRODYNAMIC SEPARATORS

Hydrodynamic separators are flow-through stormwater treatment structures with a settling or separation unit to remove sediments and other pollutants. No outside power source is required, because the energy of the flowing water allows the sediments to efficiently separate. Depending on the type of unit, this separation may occur by means of swirl action or indirect filtration. There are many different technologies available and all are housed within a structure of some type. Due to their small size, they are especially well-suited in applications where land availability is an issue.

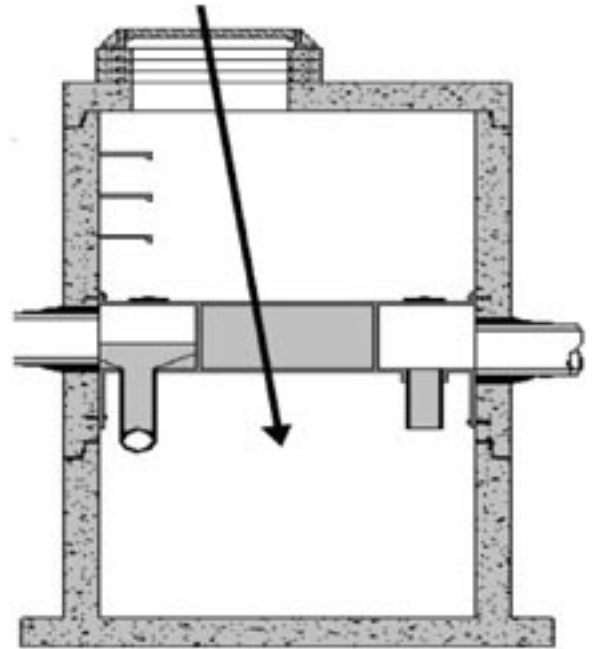

THE CONCRETE ADVANTAGE

- Precast concrete's superior strength makes it the best solution for placement under heavily loaded surface conditions
- Reductions in excavation/backfill/compaction requirements
- Concrete structures provide greater long-term durability
- Most designs utilize industry standard manholes and/or vault structures, reducing construction lead times
- Resists buoyancy in high water table applications

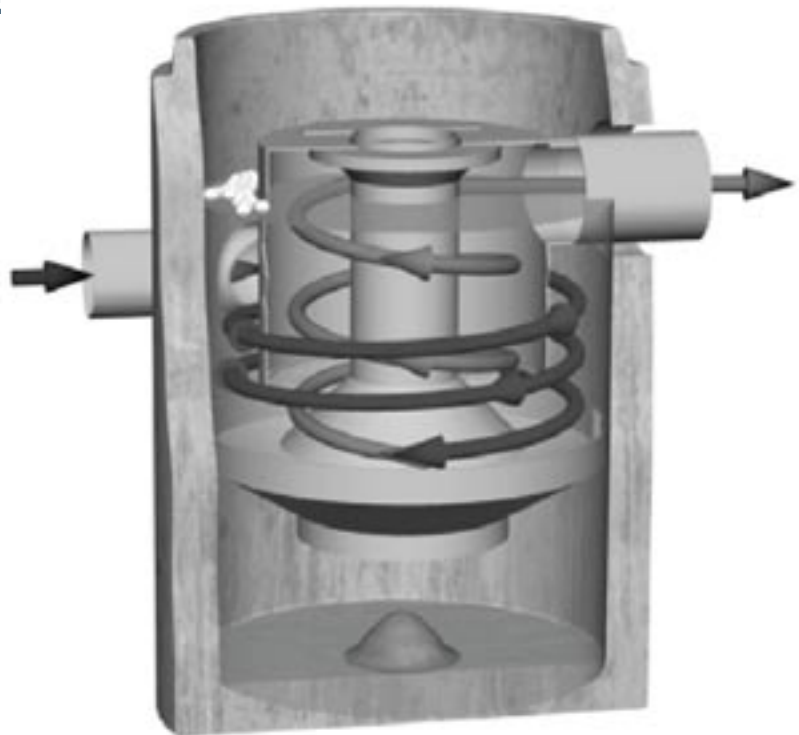

**precast
solutions**

Precast concrete stormwater treatment systems have many advantages over competing materials:

SUPERIOR STRENGTH AND DURABILITY

The strength of precast concrete gradually increases over time. Other materials can deteriorate, experience creep and stress relaxation, lose strength and/or deflect over time. The load-carrying capacity of precast concrete is derived from its own structural qualities and does not rely on the strength or quality of the surrounding backfill materials. Studies have shown that precast concrete products can provide a service life in excess of 100 years. In severe conditions, additional design options are available to extend the life of precast concrete products.

QUALITY CONTROL

Because precast concrete products typically are produced in a controlled plant environment, they exhibit high quality and uniformity. Problems affecting quality typically found on a job site – temperature, curing conditions, poor craftsmanship and material quality – are nearly eliminated in a plant environment. Precast concrete products manufactured in a quality-controlled environment and installed with highquality sealants offer a superior solution to watertightness requirements.

Standard watertight sealants are specially formulated to adhere to precast concrete, making watertight multiple-seam precast concrete structures possible.

EASE OF INSTALLATION

Setting precast concrete structures into place is easier because they do not require special rigging (such as fabric slings) to avoid structural damage. Other materials such as fiberglass can suffer structural damage during compaction. In contrast, precast concrete is less susceptible to vibratory damage while the surrounding soil is backfilled. Consequently, backfilling operations can usually proceed much faster around precast concrete structures.

For more information on Precast Concrete Stormwater Treatment products, please contact:

REDUCED WEATHER DEPENDENCY

Precast concrete increases efficiency because weather will not delay production. In addition, weather conditions at the job site do not significantly affect the schedule. Conversely, forming and placing of concrete in cast-in-place applications can cause significant delays due to poor weather.

RESISTS BUOYANCY

With a specific gravity of 2.40, precast concrete structures resist the buoyant forces associated with underground construction. In comparison, fiberglass has a specific gravity of 1.86, and high-density polyethylene (HDPE) has a specific gravity of 0.97.

CORROSION RESISTANT

Precast concrete is resistant to most corrosive substances. While no material is completely immune to chemical attack, the mix designs used to produce precast concrete can be adjusted to help withstand anticipated corrosive agents. Materials such as steel and other metals quickly deteriorate in the presence of corrosive agents, some in the presence of water alone. To better protect reinforcement from corrosion, the precast concrete strength should be designed to 4,000 psi or more.

ENVIRONMENTALLY FRIENDLY

Besides water, concrete is the most used material on earth. It is nontoxic and environmentally safe. As environmental laws heighten, especially those that prohibit pollutant discharge into rivers and lakes, precast concrete is additionally beneficial because it is made from natural materials. Precast concrete products are buried throughout the world as part of the stormwater treatment systems of nearly every modern city but do not themselves contribute to poor water quality. Precast concrete is the choice material for products used in stormwater treatment systems. Precast structures are modular, can fit any design situation, are produced in a quality-controlled environment and are ready to install immediately upon arrival at the job site. Precast stormwater treatment components are easily produced to be watertight, durable during storage and transportation, easy to install, less vulnerable than competing products to damage during backfill, and are environmentally safe during operation.

**precast
solutions**